

| | |
|---------------------------|------------|
| Wydanie <i>Edition</i> | 01 |
| Data <i>Date</i> | 01-09-2017 |

ZAMEK 8 CASTLE 8

Numer katalogowy
catalogue number **83008**













1. Informacje techniczne *Technical information*

| | |
|---|----------------------------------|
| Grupa wiekowa <i>User age</i> | do 14 lat |
| Maksymalna wysokość swobodnego upadku <i>Max. free fall height</i> | 1,28 m |
| Największa część <i>Largest part</i> | Pomost <i>Bridge</i> |
| Wymiary największej części <i>Largest part dimensions</i> | 1,93 x 1,16 x 1,14 m |
| Masa największej części <i>Largest part weight</i> | 100 kg |
| Masa największego fundamentu <i>Largest foundation weight</i> | 60 kg |
| Zgodność z normami <i>Accordance with standards</i> | EN 1176-1:2008 EN 1176-3:2008 |

2. Wykaz narzędzi

Tools list

| | | | | | |
|---|---|---|---|---|---|
|  |  |  |  |  |  |
|  |  |  |  x2 | | |

3. Wykaz części

Parts list

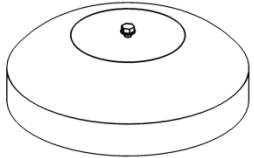
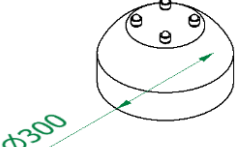
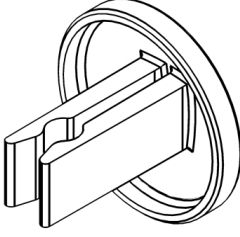
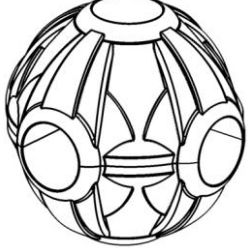
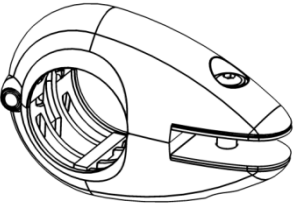
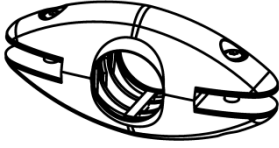
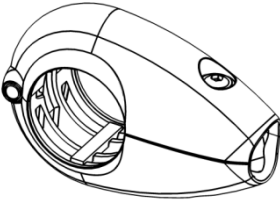
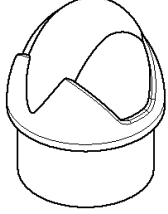
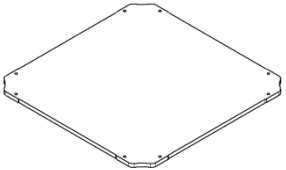
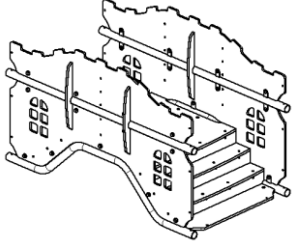
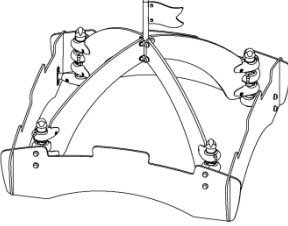
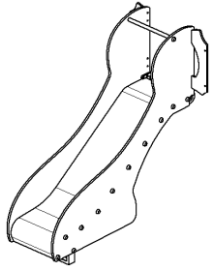
| | | | | | | | |
|---|---|--|---|-------|-------------|------|-------------|
|  Ø500 |  Ø300 |  |  | | | | |
| B500x1 | Szt. Pcs 1 | B300x4 | Szt. Pcs 12 | ZS-1* | Szt. Pcs 31 | KL* | Szt. Pcs 15 |
|  |  |  |  | | | | |
| UC-1* | Szt. Pcs 65 | UC-2* | Szt. Pcs 15 | UC-3* | Szt. Pcs 16 | ZS-2 | Szt. Pcs 8 |
|  |  |  |  | | | | |
| PK-1000* | Szt. Pcs 2 | MS | Szt. Pcs 1 | D4 | Szt. Pcs 2 | ZJ | Szt. Pcs 1 |

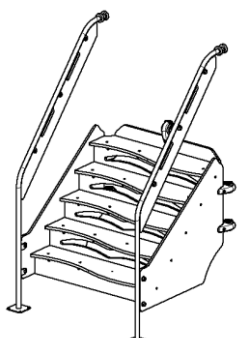
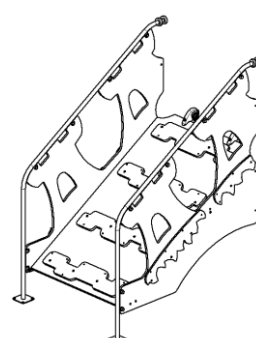
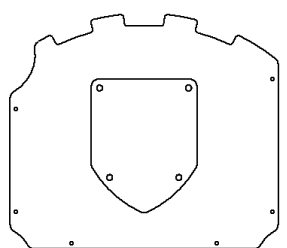
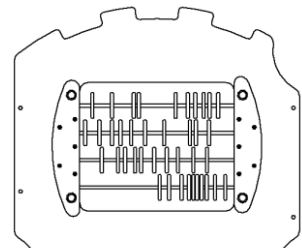
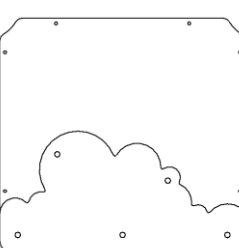
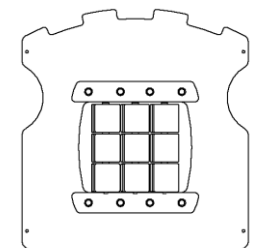
| | | | | | | | | | | | |
|---|-------------|---|---|-------------|---|--|-------------|---|---|-------------|---|
|  | | |  | | |  | | |  | | |
| SCH | Szt. Pcs | 1 | TRP | Szt. Pcs | 1 | BAR-1 | Szt. Pcs | 1 | LIC | Szt. Pcs | 1 |
|  | | |  | | | | | | | | |
| S-A1 | Szt. Pcs | 2 | XO | Szt. Pcs | 1 | | | | | | |

* patrz – instrukcja szczegółowa
see – detailed instruction

4. Rury

pipes

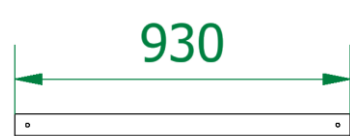
| | | | | | | | | | | | |
|------|----------|---|--|--|--|--|--|--|--|--|--|
| RO-1 | Szt./Pcs | 8 |  | | | | | | | | |
| RO-2 | Szt./Pcs | 1 |  | | | | | | | | |
| RO-3 | Szt./Pcs | 7 |  | | | | | | | | |

5. Etapy instalacji

Installation steps

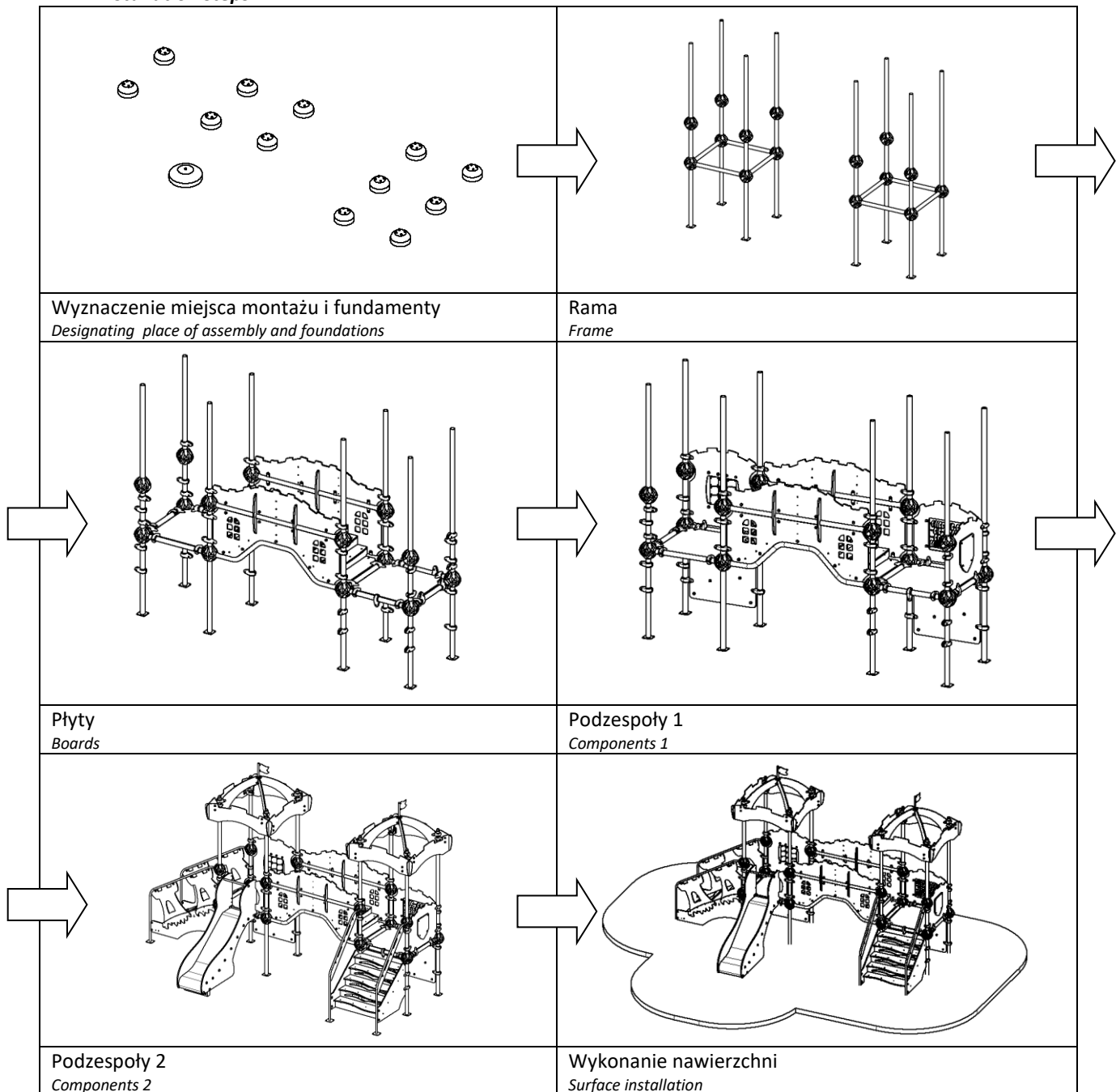

6. Fundamenty i powierzchnia zderzenia

Foundations and impact area

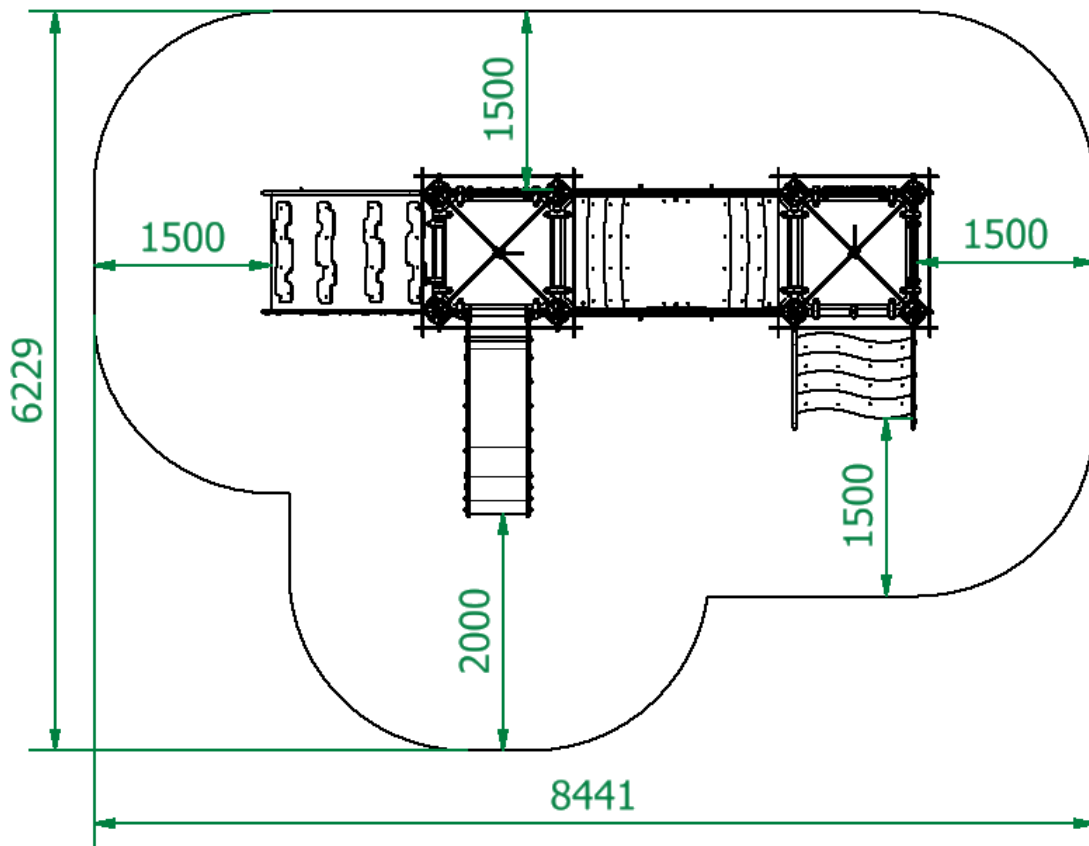
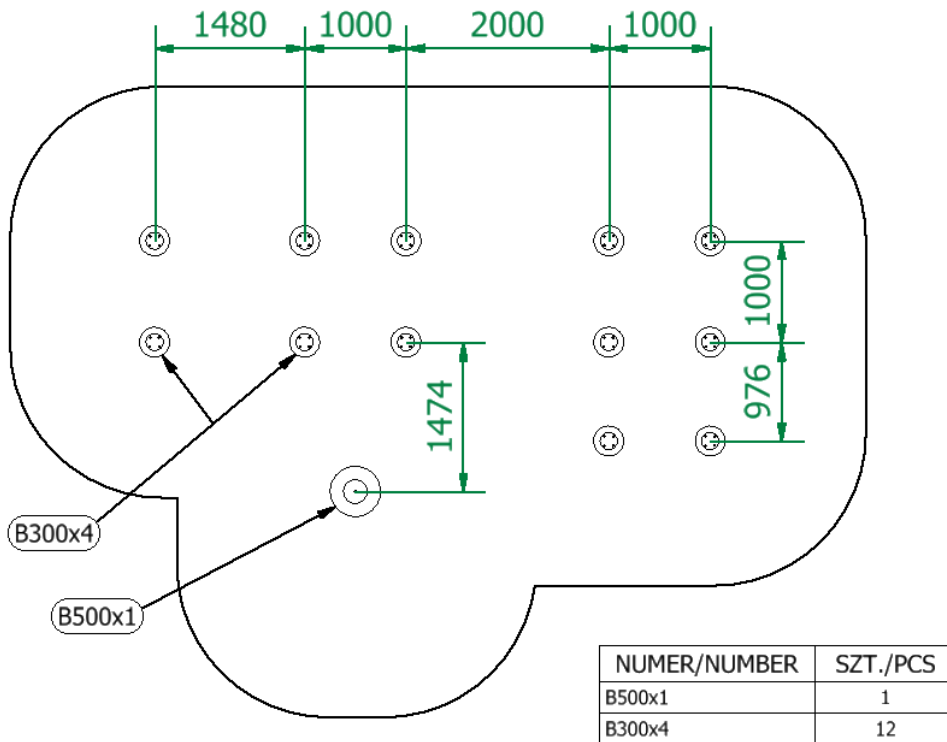

7. Rama Frame

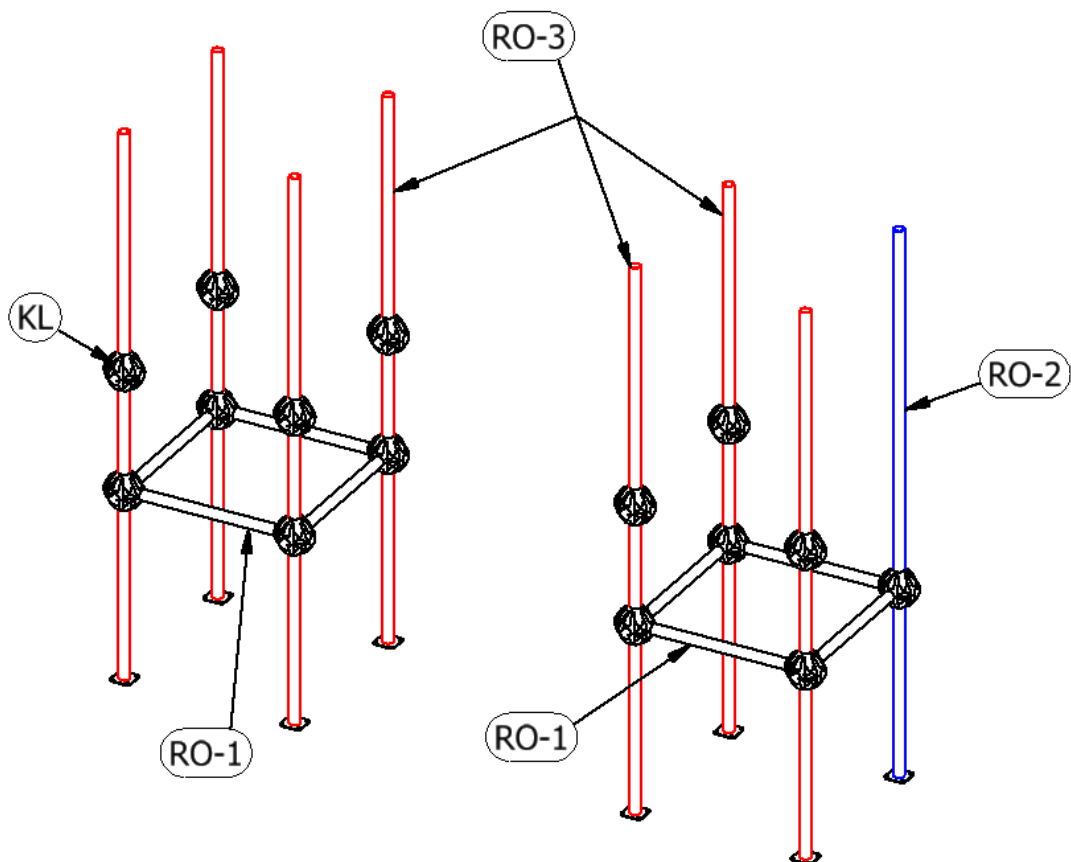
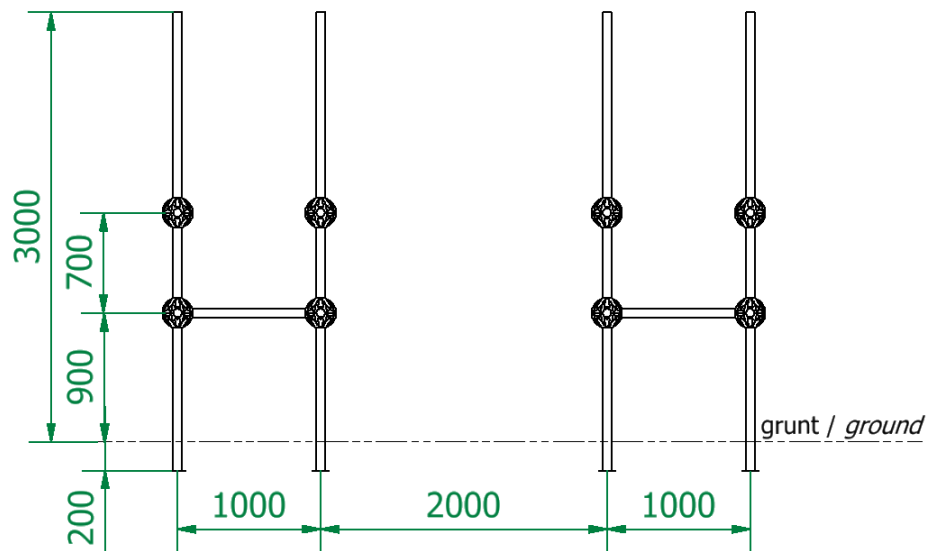

8. Płyty / most Boards / bridge

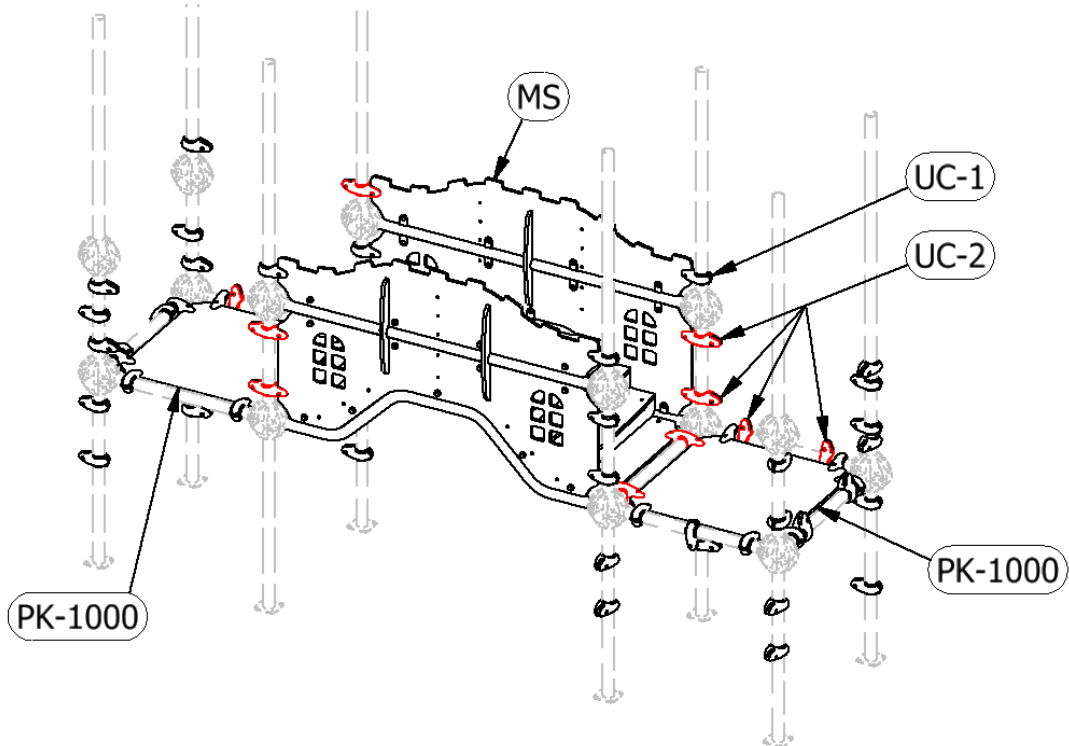

Zalecane wstępne nałożenie uchwytów (bez dokręcania) / Recommended initial assembly of holders (without tightening)

9. Podzespoły Components

